



Fig. 13—Removing Windshield Glass

10. With the windshield out of position, curl back the lip of the rubber glass channel and remove the upper reveal molding (fig. 14).

NOTE: The windshield upper reveal molding is retained by a molded groove in the windshield rubber channel. Due to its retaining flange this molding cannot be removed from the groove in the rubber channel until the windshield is almost completely removed from the body opening.

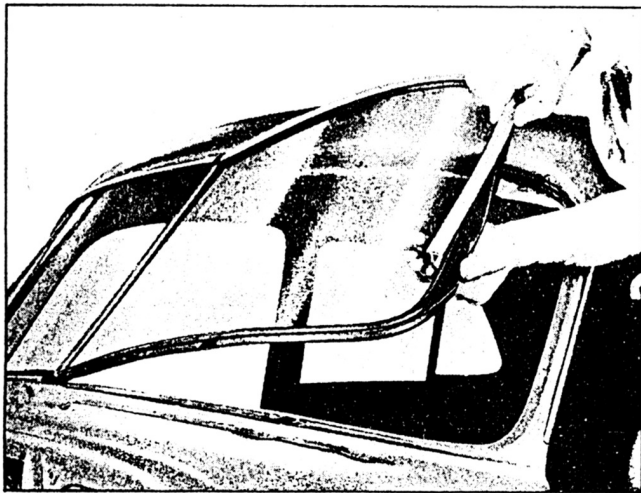

Fig. 14—Removing Upper Reveal Molding

11. Loosen the seal of weatherstrip cement between the glass and rubber channel. Disengage the rubber weatherstrip from the glass and lift glass out of body opening (fig. 15).

Installation

Before new glass installation, inspect the contour of the pinch-weld flange for any irregularities and correct. New glass can be used as a template. Using a scraper and oleum spirits, remove all old cement and dry thoroughly. Also, clean rubber

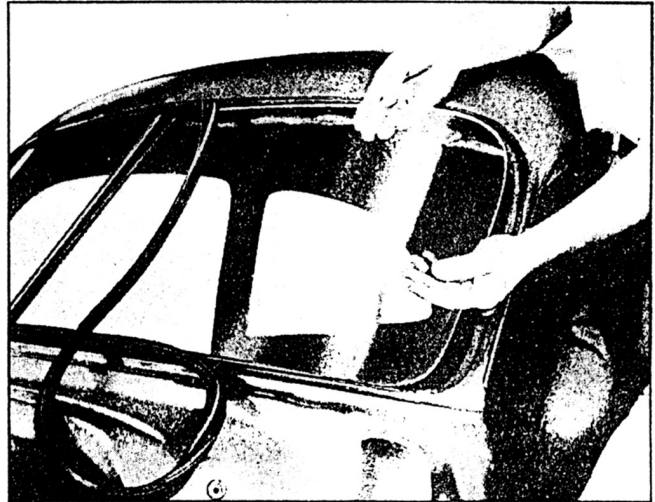

Fig. 15—Disengaging Glass from Weatherstrip

glass channel. Do not use gasoline or similar product to clean the rubber channel.

1. Before installation, apply 3-M Autobody Sealer to the flanges of the windshield opening as indicated in Figure 16.

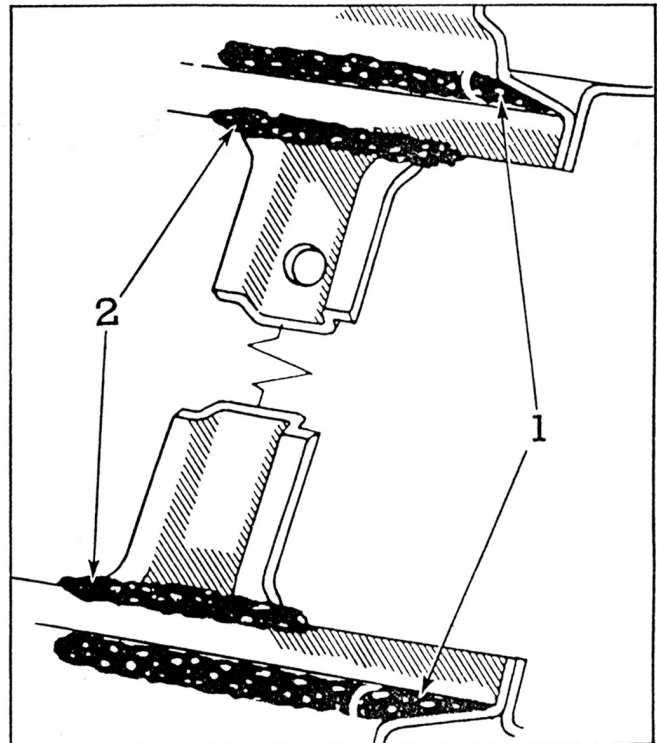

Fig. 16—Applying 3-M Autobody Sealer to Windshield Opening

- a. Apply a $\frac{3}{16}$ " to $\frac{1}{4}$ " continuous bead of sealer along the outside rabbet of the opening just below the pinch-weld as indicated at (1).
- b. Apply a $\frac{3}{16}$ " to $\frac{1}{4}$ " bead of sealer across the windshield center bar at top and bottom as indicated at (2).

2. Insert a strong cord into the pinch-weld cavity of the windshield rubber channel.
3. Install windshield glass into rubber channel. Work channel over edge of glass all around except at the center division edge.
4. To facilitate easy installation, use a mild soap and water solution and apply this solution into the upper reveal molding groove in the rubber channel and also into the center division glass cavity of the rubber channel.
5. Insert the inner end of the reveal molding into the groove in the glass rubber channel six inches from the center division. Then slide it towards the center division until the outer side section of the molding comes into alignment with the rubber channel. When in alignment, insert the top and side sections into the rubber channel and press firmly into place.
6. Lower the glass and its channel into the windshield body opening and move the glass so that its inner edge enters into the center division groove of the glass channel.
7. With a helper, position and hold the glass and its channel firmly in the windshield body opening. Then, use the string previously placed in the pinch-weld cavity of the rubber channel to pull the inner lip of the channel over the pinch-weld (fig. 17).

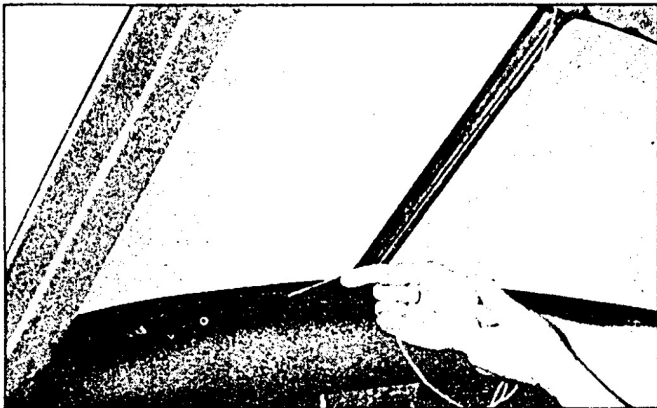

Fig. 17—Raising Inner Lip of Channel Over Pinch-Weld

8. After the assembly is in position and before the moldings are installed, seal as indicated (fig. 18) using 3-M Weatherstrip Adhesive in a sealing gun.
 - a. Seal between outer lip of rubber and glass as indicated at (3), completely around opening.
 - b. Before garnish molding is installed, seal under inner pinch-weld lip of rubber channel as indicated at (4).
9. To complete sealing, seal all outside reveal molding attaching screw holes with 3-M Autobody Sealer.

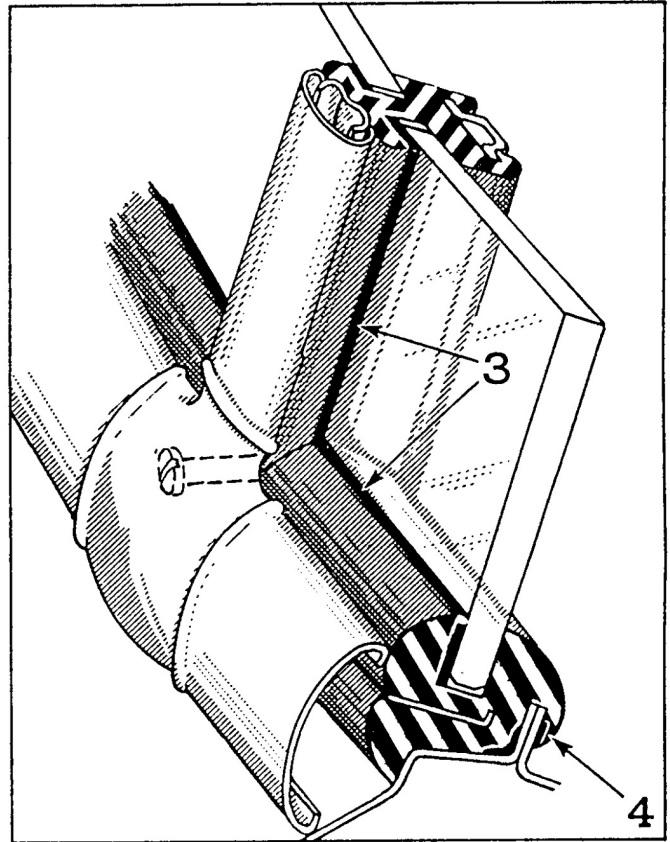

Fig. 18—Sealing after Glass and Channel are in Position

10. Replace garnish moldings, outside lower reveal molding, center division reveal molding and escutcheon, and wiper arms and blades.

WINDSHIELD ASSEMBLY (1953)

All 1953 Chevrolet body styles utilize a large one piece windshield. The removal and installation procedure is basically the same for all body styles, with the exception of the molding removal.

Before windshield removal, protect the paint finish by masking around the windshield opening. Also, place a suitable covering across the hood and fenders.

Removal

1. Remove windshield wiper blade and arm assemblies and wiper transmissions. Lower top on Convertibles.
2. Remove windshield garnish moldings, escutcheon and rear view mirror. On convertibles remove screw retaining side reveal molding to upper windshield pillar.
3. On Sport Coupes, remove rain deflector and single screw from each windshield side reveal molding.